

COMBO ICE MAKER/REFRIGERATOR

Model COMBO 29WHTP

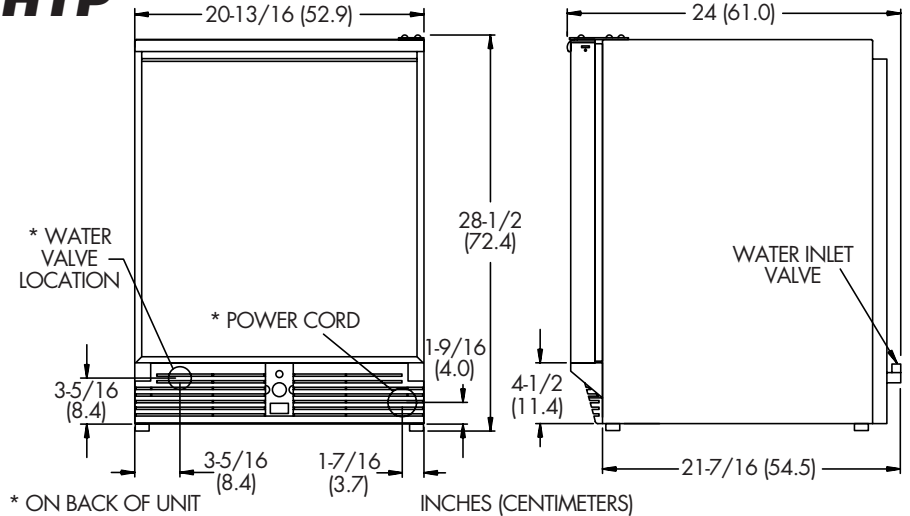
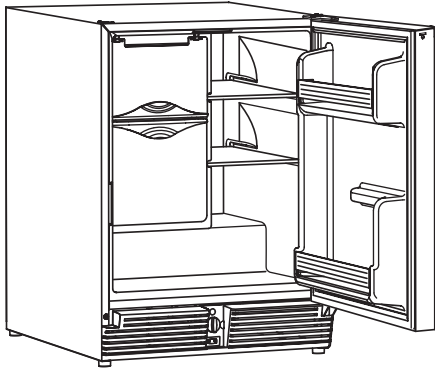

FEATURES

1. **Manual defrost ice maker**
2. **Anodized aluminum door handle and frame**
3. **Stainless hinges and mounting hardware**
4. **Specially coated grille**
5. **Travel pin – Factory installed**
6. **Front vented for built-in installation**
7. **2.1 cubic feet of refrigeration**
8. **No drain required for water**
9. **Conserves water**
10. **Field reversible door**
11. **In-door storage**
12. **Tempered glass shelves**

ADDITIONAL FEATURES:

- See through, removable ice bucket, stores 13 lbs. of ice
- Available in 110/115V 60 cycle or 220/230V 50/60 cycle
- Shipping weight: 97 lbs.
- White vinyl clad steel cabinet and door panel

BENEFITS

- Greater daily ice production capacity. Less affected by warmer ambients. Produces up to 18 lbs. of ice per day in a 70°F ambient temperature.
- Corrosive and UV resistant.
- Corrosive resistant.
- UV resistant.
- Helps keep the door secure when en route. Pre-installed at factory.
- No need for extra fans, air space, or special venting to the outside of the cabin. **Do not obstruct front grille.**
- Ice making and refrigeration in one compact unit.
- Easy and inexpensive to install. Only needs 1/4" outside diameter water line connection.
- Only 2-1/4 gallons of water needed to produce approximately 18 lbs. of ice.
- Flexible installation capabilities to ensure easy access.
- 2 door shelves with clear, flexible bottle retainers for greater storage.
- Generous amount of shelving space, easy to clean, helps to contain spills.